

Cold forming behaviour of security steels

ThyssenKrupp
high protect

SECURE

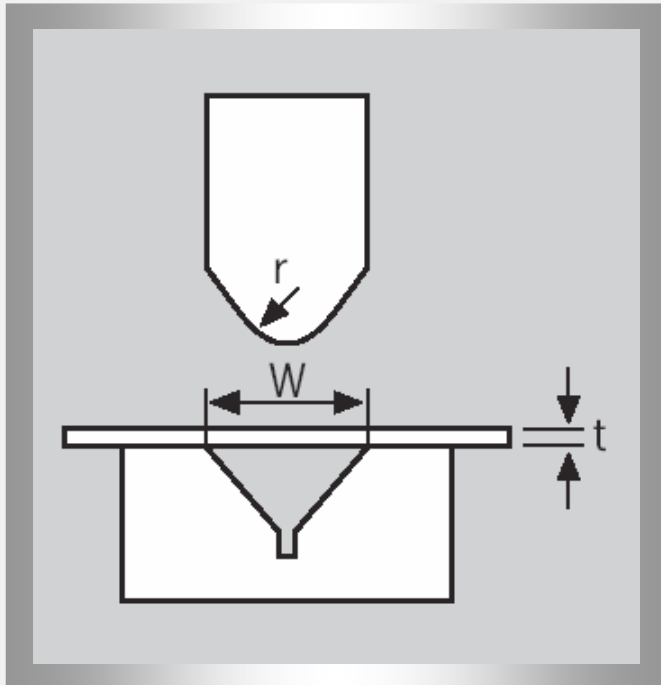

Recommendations for minimum bending radii

Grade	Thickness [mm]	r/t	
			⊥
SECURE 400	$t \leq 8$	7	5
SECURE 500	$t \leq 8$	8	6
SECURE 450	$t \leq 8$	5	4
SECURE MS special	$t \leq 3.5$	3.5	3

|| = bending line parallel to rolling direction

⊥ = bending line perpendicular to rolling direction