

# Bending radii for cold forming of quenched and tempered special structural steels

ThyssenKrupp  
high strength

N-A-XTRA®

and

ThyssenKrupp  
high strength

XABO®

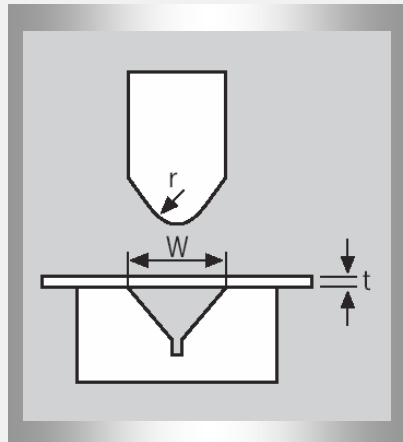

Steel grade	Plate thickness t [mm]			
	t ≤ 6		t > 6 ≤ 16	
		⊥		⊥
N-A-XTRA® 700	2,5 t	2,0 t	3,0 t	2,0 t
N-A-XTRA® 800	3,0 t	2,5 t	3,5 t	2,5 t
N-A-XTRA® 890 / 960 / 1100	3,5 t	3,0 t	4,0 t	3,0 t

|| = bending axis parallel to rolling direction

⊥ = bending axis perpendicular to rolling direction

For bend angles ≤ 90°

For more information see processing recommendation brochure

